

図1 試験機概寸



図2 ステージ寸法



図4 圧子取付け部寸法

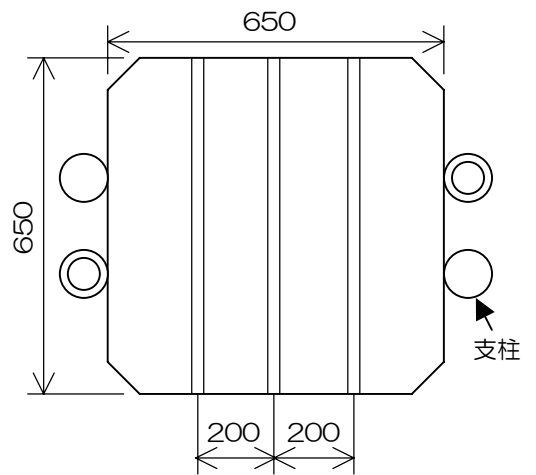

図3 引張試験片取付け部概寸

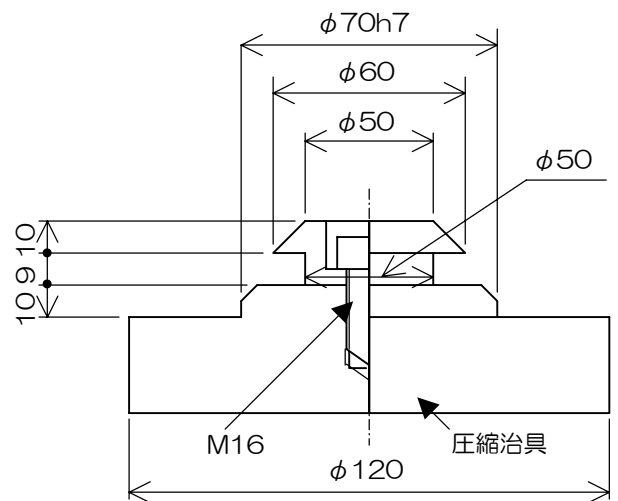
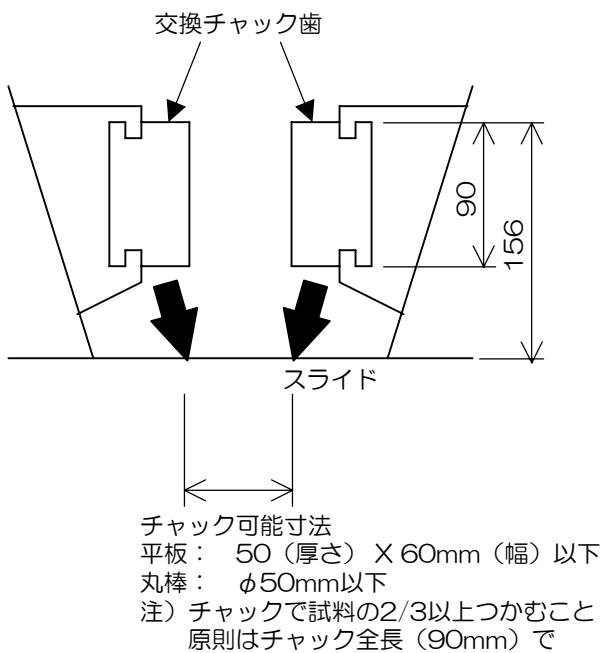
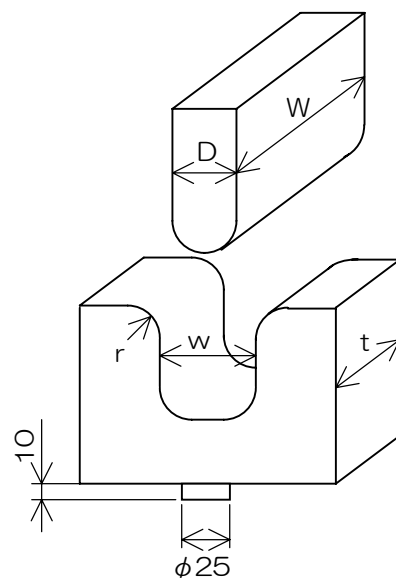

図5 型曲げ試験治具 (表1, 2参照)